



ASSEMBLY INSTRUCTIONS

SS1507



BASE SIZE: 1.520m x 0.685m

**CONGRATULATIONS ON PURCHASING A SMART STORE SHED.
BEFORE YOU BEGIN THE ASSEMBLY PLEASE NOTE SOME IMPORTANT POINTS:**

BEFORE YOU START:

- *Read all instructions carefully*
- *Identify all parts and check quantities against parts list*
- *Select a level site*
- *Do not mark cladding with pencil as lead can cause corrosion to cladding*

SAFETY:

- *Do not attempt to build your shed in high winds*
- *Beware of sharp edges, recommend use of gloves*
- *Protect your eyes and ears*
- *For ease of assembly, use a friend to help*

TOOLS REQUIRED:



DRILL



RIVETER



PHILLIPS DRILL BIT



3.5mm DRILL BIT



LADDER



HAMMER



NAIL PUNCH



TAPE MEASURE















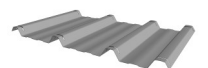

PEN

WARRANTY REQUIREMENTS:

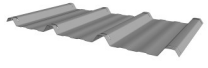
Following are the minimum requirements for cladding used in Smart Store Sheds.

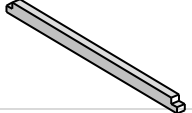
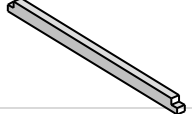
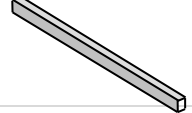
- *Wash all surfaces annually using a hose and soft nylon brush.*
- *Within 2 km of coast – wash every 3 months as above. After a storm, wash the cladding and the gutters as soon as possible to remove any highly corrosive salt deposits.*
- *Volcanic Ash Fallout – wash as soon as possible, removing fall out from roof and gutters.*
- *Do not allow manures, chemicals or other corrosive materials to have direct contact with cladding.*

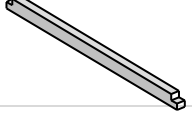
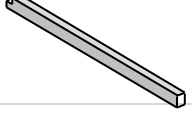
SS1507 PARTS LIST

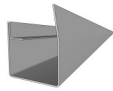
DESCRIPTION	QTY	DIAGRAM	CHECKED	DESCRIPTION	QTY	DIAGRAM	CHECKED
CLADDING				FLASHINGS			
			CHECKED				CHECKED
Wall Sheets 1.810 m	5		<input type="checkbox"/>	Door Side 1.810 m	2		<input type="checkbox"/>
Front Wall Unpunched 3/4 Sheets 1.850 m	2		<input type="checkbox"/>	Door Jamb 1.850 m	2		<input type="checkbox"/>
Side Wall 1/2 Sheets 1.810 m	2		<input type="checkbox"/>	Door Brace 0.980 m	2		<input type="checkbox"/>
Roof 0.885 m	3		<input type="checkbox"/>	Barge 0.885 m	2		<input type="checkbox"/>
Punched Full Sheet for Door 1.810 m	1		<input type="checkbox"/>	Padbolt Support 0.195 m	1		<input type="checkbox"/>
TIMBER				Spouting 1.550m	1		<input type="checkbox"/>
Bottom Plates - H4 (Green) Front/Back 1.520 m	2		<input type="checkbox"/>	HARDWARE			
Bottom Plates - H4 (Green) Sides 0.685 m	2		<input type="checkbox"/>	Hardware Pack	1		<input type="checkbox"/>
Top Plate - H1 (Red) Back 1.520 m	1		<input type="checkbox"/>	Paint & Brush	1		<input type="checkbox"/>
Top Plate - H1 (Red) Front 1.520 m	1		<input type="checkbox"/>	OPTIONAL			
Top Plate - H1 (Red) Sides 0.685 m	2		<input type="checkbox"/>	Bolt Down Kit	1		<input type="checkbox"/>
CHANNELS							
Door Top/Bottom 0.545 m	2		<input type="checkbox"/>				
				DATE: _____ PACKED BY: _____			

PARTS LOCATION

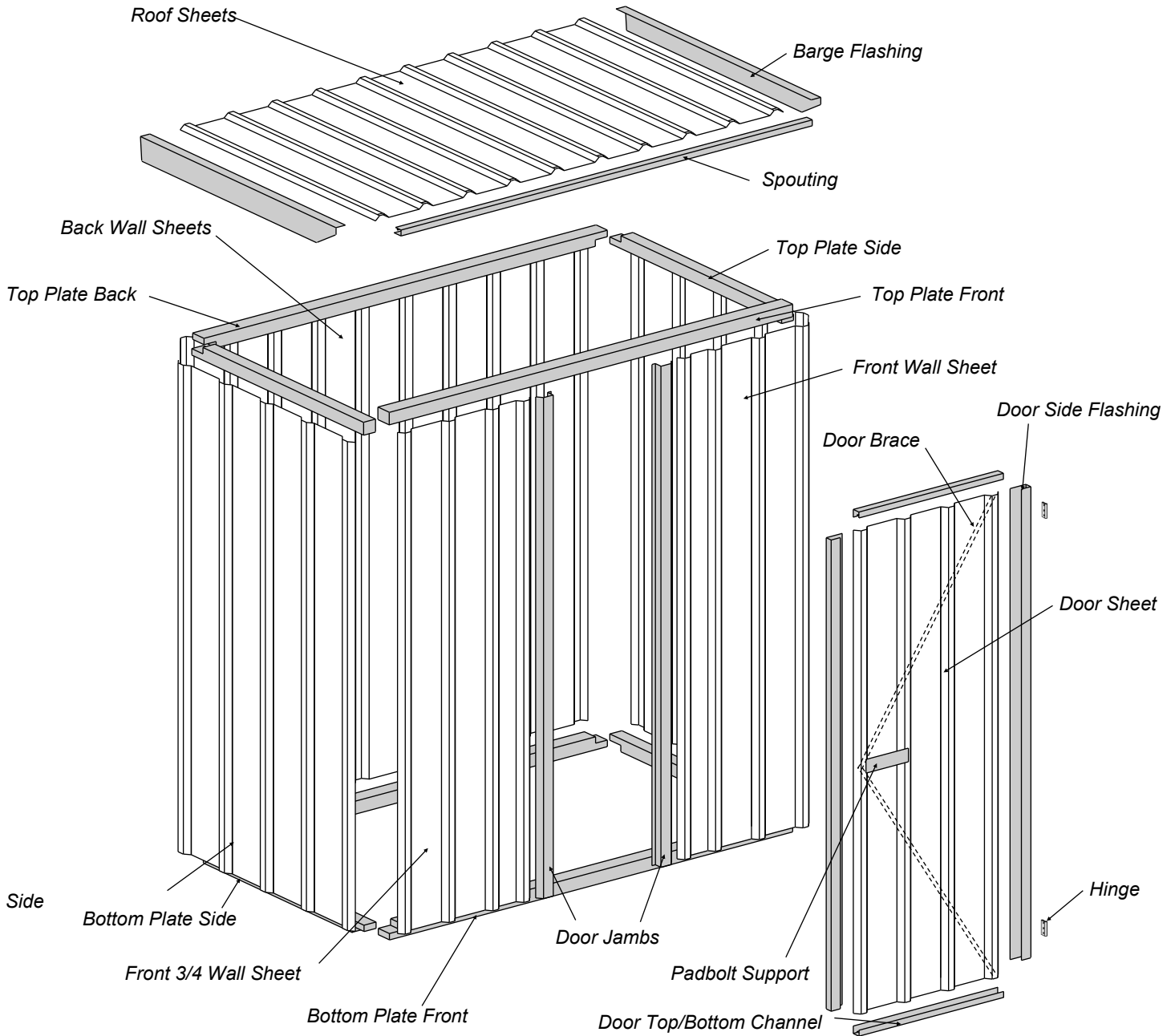

QUICK OVERVIEW

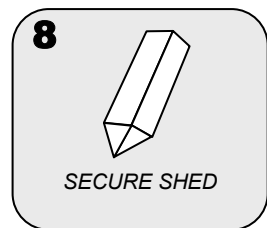
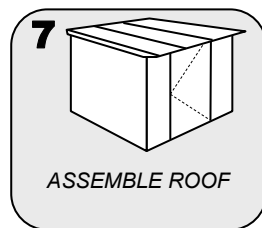
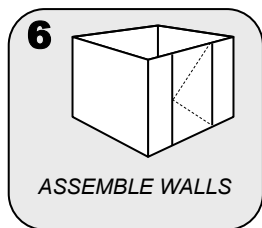
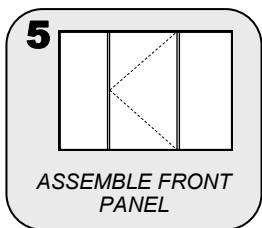
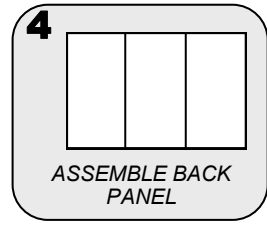
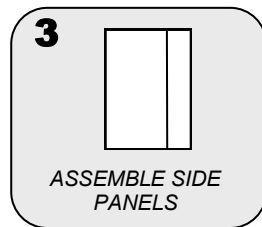
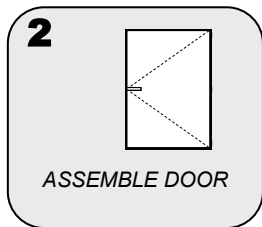
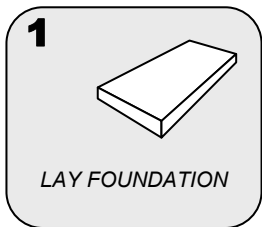



No doubt by now you will have decided what sort of base you are putting down.

Please read the section that applies to your situation.

If you choose to pour a concrete base you will need to decide whether you wish to raise the base plate of your shed. This allows the cladding to protrude below the surface of the concrete and ensures a water tight pad.

See concrete pad specifications below

By choosing this option you will need to make the pad to the specification below.

RAISED BASE PLATE OPTION

(For sheds placed on a raised concrete floor)

- During construction, you may raise the bottom timber plate to allow the wall cladding to protrude 20mm below the bottom plate. This will stop water flowing between the bottom plate and the concrete floor.

See note on page 7.

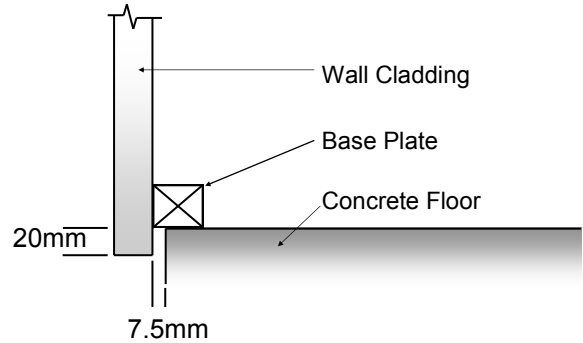

CONCRETE SLAB FOR RAISED BASE PLATE SHED

To build a raised concrete slab for your shed to sit on, we recommend the following:

- The raised slab size should be 15mm smaller than the base size of the shed and at least 30mm above ground line.
- The slab should be 80mm thick in the middle and 100mm thick around the edges.
- The slab should be laid on a solid or compacted base.
- Plastic sheeting under slab will prevent moisture coming through from underneath.

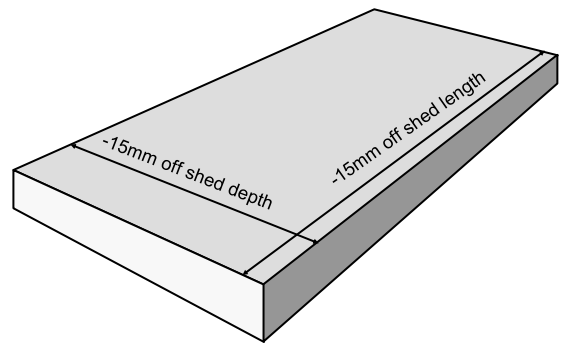

SMART STORE WOODEN FLOOR

- The optional Smart Store kitset wooden floor is precut and designed to be fitted into the shed after the shed is assembled.
- Assemble shed as per instructions and fit floor last. (see page 12 for details).

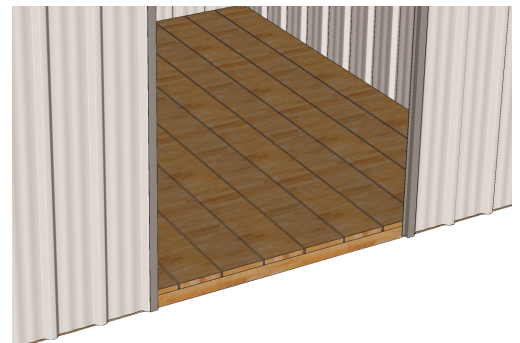

ASSEMBLE DOOR



SELECT:

- 1 x 1.810 m Door Sheet
- 2 x 0.545 m Door Top/Bottom Channels
- 2 x 1.810 m Door Side Flashings
- 2 x 0.980 m Door Braces
- 1 x Padbolt Support Flashing
- 2 x Hinges
- 32 x Rivets

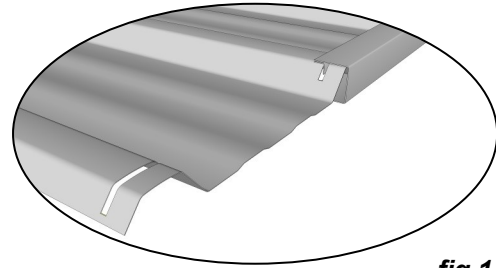

fig.1

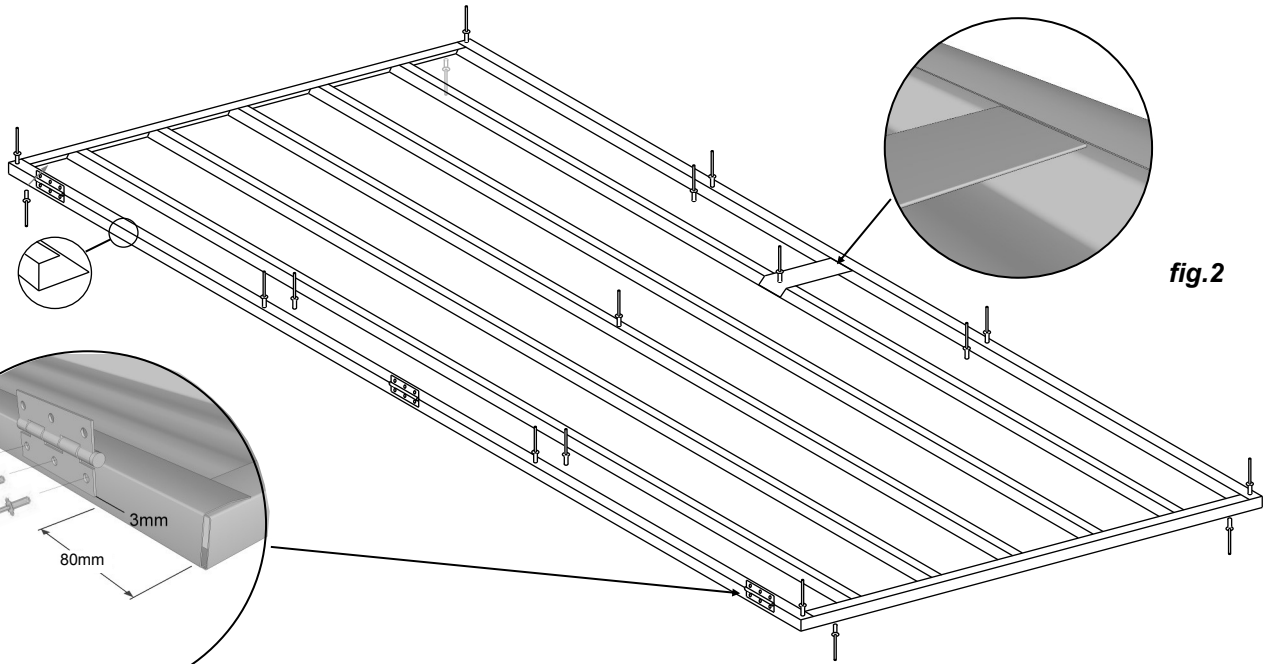
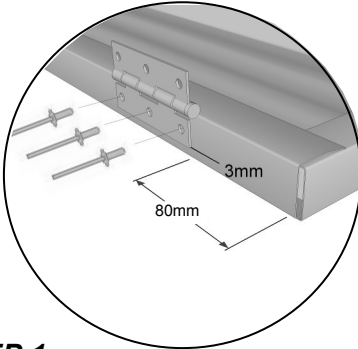

fig.2



STEP 1:

- Lay out door sheet on a flat.
- Slide door top and bottom channels on each end as shown in **fig. 1**
- Position door side flashings and assemble door as shown.
- Drill and rivet as per diagram, ensuring rivets penetrate into door sheet.

STEP 2:

- Attach hinges to door side channel using rivets provided.
- Using one rivet, attach padbolt support as shown in **fig. 2**

STEP 4:

- Rivet door brace flashings onto back of door as shown. Where possible, rivet from front of door.
- Ensure the door brace flashings are approx 70mm from top and bottom of door, and 10mm from the side to clear top and bottom timber plate, when hung.

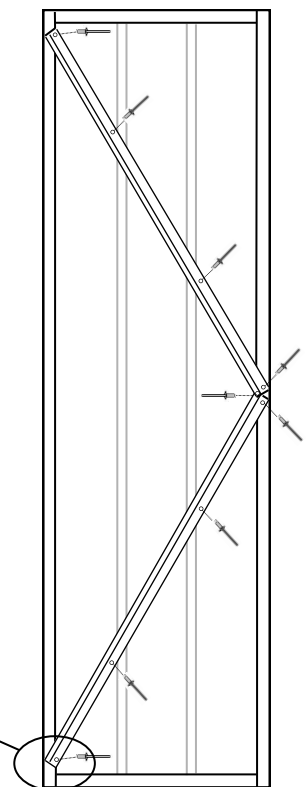
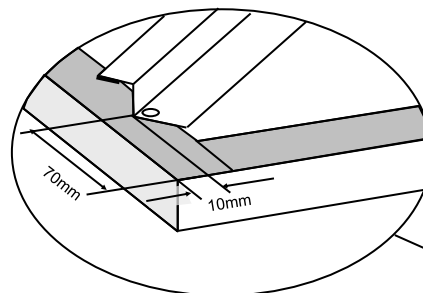

ASSEMBLE SIDE PANELS



SELECT:

- 2 x 1.810 Wall Sheets
- 2 x 1.810 1/2 Wall Sheets
- 2 x 0.685 Top Plates (Red)
- 2 x 0.685 Bottom Plates (Green)
- 32 x 30mm Galv Clouts
- 4 x Rivets

IMPORTANT—IF YOU CHOOSE TO RAISE YOUR TIMBER BASE PLATE –READ THE FOLLOWING;

For sheds with Raised Base Plate option only (see page 5), deduct 30mm from measurement shown between Top and Bottom Plates on all wall panels, so cladding protrudes 20mm below bottom plate.

STEP 1:

- Lay out 1 x Top Plate and 1 x Bottom Plate on a flat surface as shown (corner cut outs to face outwards). **Measurements between Top and Bottom plates are critical to ensure wall panels fit together.**

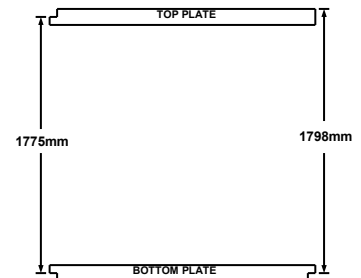

STEP 2:

- Place 1 x 1.810 wall sheet and 1 x 1/2 wall sheet on top of timber plates, with sheets flush with each other.
- Rivet sheets together on overlaps as shown.

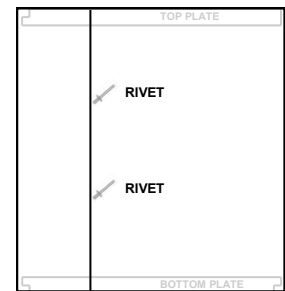

STEP 3:

- Nail wall sheets to the Top Plate at each end making sure that the top of the sheets are flush with the top of the Top Plate and the sides of the wall sheet overhang the Top Plate by approx 13mm as shown.
- Check that the Top Plate is straight then nail along the wall sheet to the Top Plate, two clouts per pan (see fig. 1).

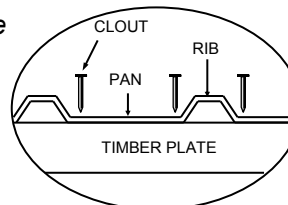
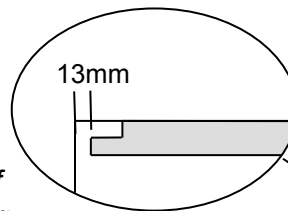

fig.1

Std Shed — Bottom Plate will protrude below wall sheet by approximately 10mm.

Raised base plate shed — Wall sheet will protrude below the Bottom Plate by 20mm.

STEP 4:

- Nail the wall sheets to the Bottom Plate at each end ensuring each side of wall sheets overhangs the end of Bottom Plate by 13mm. Check that the distance between the Top and Bottom Plates is correct. (As per diagram in step 1)
- Check that the Bottom Plate is straight then nail the wall sheets to the Bottom Plate, two clouts per pan (see fig. 1).

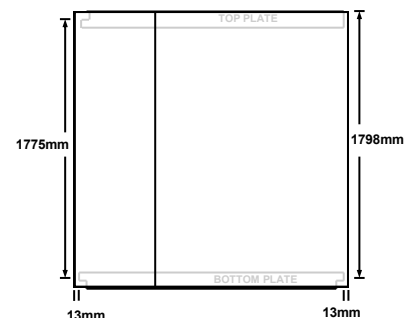

Repeat with second side panel ensuring Top Plate is positioned in the OPPOSITE direction to the first side panel, as shown.

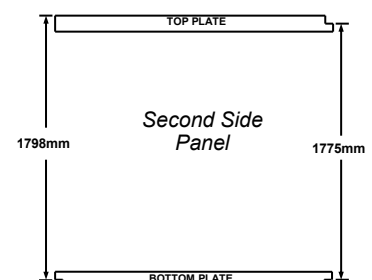

ASSEMBLE BACK PANEL

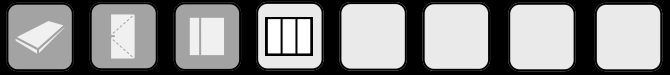

SELECT:

- 3 x 1.810m Wall Sheets
- 1 x 1.520 m Top Plate (Red)
- 1 x 1.520 m Bottom Plate (Green)
- 36 x 30mm Galv Clouts
- 4 x Rivets

IMPORTANT—IF YOU CHOOSE TO RAISE YOUR TIMBER BASE PLATE –READ THE FOLLOWING;

For sheds with Raised Base Plate option only (see page 5), deduct 30mm from measurement shown between Top and Bottom Plates on all wall panels, so cladding protrudes 20mm below bottom plate.

STEP 1:

- Lay out 1 x Top Plate and 1 x Bottom Plate on a flat surface as shown (corner cut outs to face inwards).

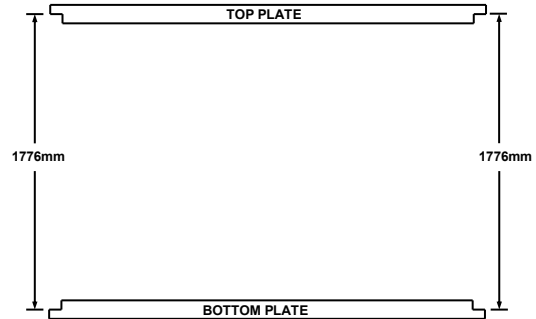

STEP 2:

- Place 3 x 1.810 m wall sheets on top of timber Plates with bottom of sheets flush with each other.
- Rivet the sheets together on overlaps as shown.

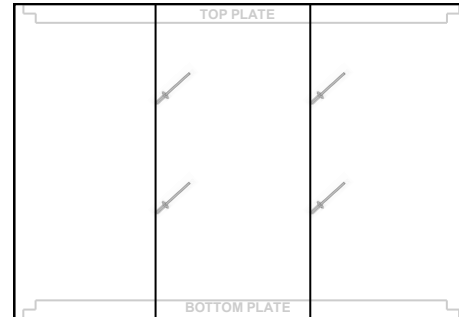

STEP 3:

- Nail the wall sheets to the Top Plate at each end making sure that the top of the sheets are flush with the top of the Top Plate and that the sides of the wall sheets overhang the Top Plate by 15mm as shown.
- Check that the Top Plate is straight then nail wall sheets to the Top Plate, using two clouts per pan.

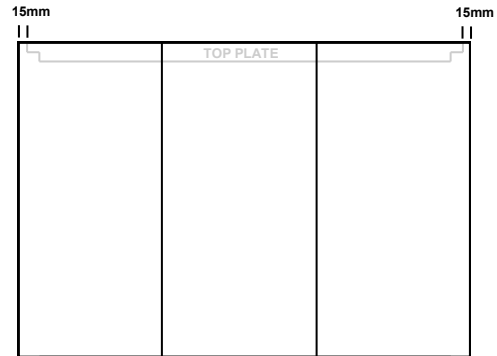

Std Shed — Bottom Plate will protrude below wall sheet by approximately 10mm.

Raised base plate shed — Wall sheet will protrude below the Bottom Plate by 20mm.

STEP 4:

- Nail the wall sheets to the Bottom Plate at each end, ensuring that each side of the wall sheets overhangs the Bottom Plate by 15mm and that the distance between the Top and Bottom Plates is correct. (As shown)
- Check that the Bottom Plate is straight then nail wall sheets to the Bottom Plate, using two clouts per pan.

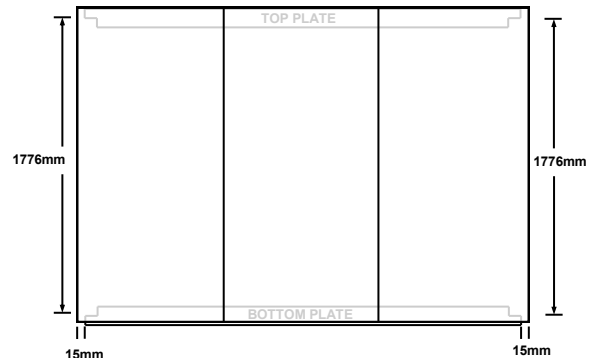

ASSEMBLE FRONT PANEL



SELECT:

- 2 x 1.850 3/4 Wall Sheets
- 1 x 1.520 Top Plate (Red)
- 1 x 1.520 Bottom Plate (Green)
- 2 x 1.850 Door Jamb Flashings
- 28 x 30mm Galv Clouts
- 17 x Rivets

IMPORTANT—IF YOU CHOOSE TO RAISE YOUR TIMBER BASE PLATE –READ THE FOLLOWING;

For sheds with Raised Base Plate option only (see page 5), deduct 30mm from measurement shown between Top and Bottom Plates on all wall panels, so cladding protrudes 20mm below bottom plate.

STEP 1:

- Lay out 1 x Top Plate and 1 x Bottom Plate on a flat surface as shown

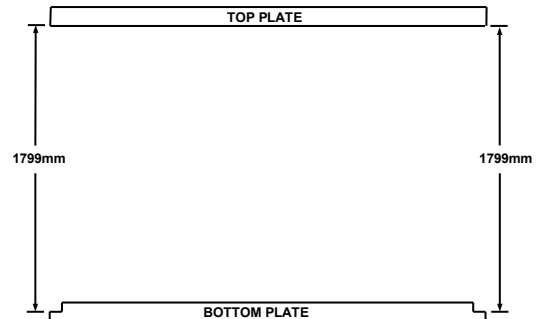

STEP 2:

- Using 2 x 30mm clouts, nail the Door Jamb Flashing flush with the top of the Top Plate at the correct measurement as shown in plan view. Pre drill holes using a 3.5mm drill bit
- Check the distance between the top and bottom plates then use a further 2 x 30mm clouts to nail the Door Jamb Flashings to the bottom Plate. Pre drill holes.

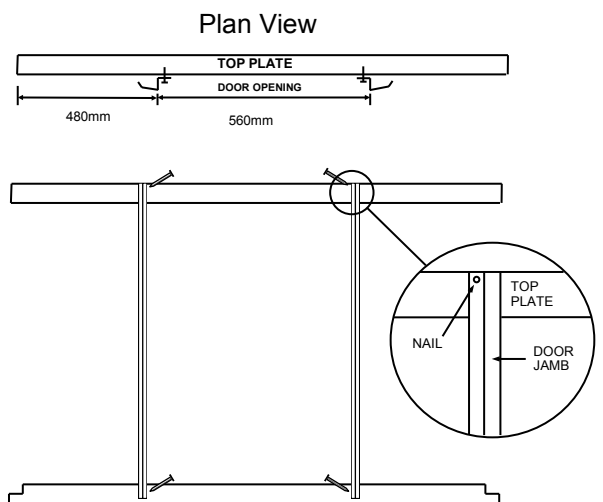

STEP 3:

- Place 2 x Wall Sheets on timber. Make sure the narrow pans are next to the door.
- Ensure that the top of the sheets are flush with the top of the Top Plate and that the sides of the wall sheets overhang the Top Plate by 15mm as shown. Nail wall sheets to Top Plate (two clouts per pan)
- Nail the wall sheets to the Bottom Plate making sure that the Plates are the correct distance apart and that the sides of the wall sheets overhang the Bottom Plate by 15mm.
- Drill & rivet Door Jamb Flashings to wall sheets using four rivets equally spaced on each side.

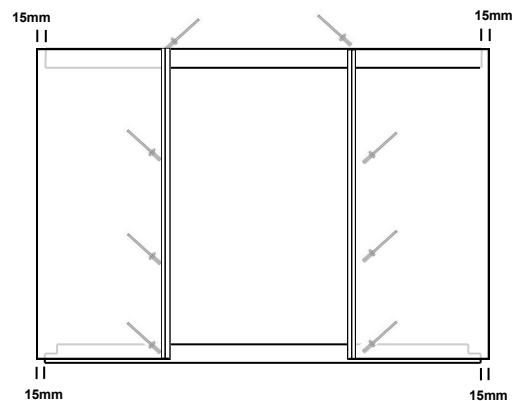

NOTE: Door can be hinged on either side.

STEP 4:

- Place the door on the panel (In open position, approx 5mm below top plate). Using two rivets, rivet the top and bottom hinges to the Door Jamb Flashing.
- Ensure the door closes properly, then fit remaining rivets.

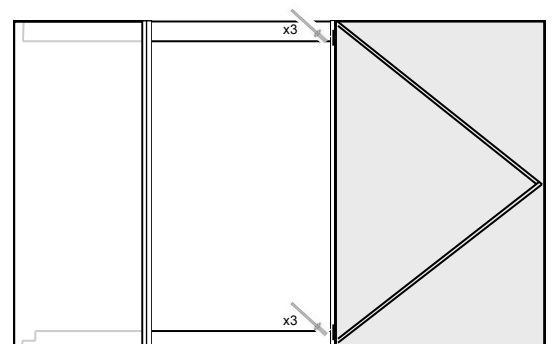

WALL PANEL ASSEMBLY



SELECT:

- 4 x Pre-made Wall Panels
- 12 x 40mm Screws
- 4 x 75mm Screws
- 16 x Rivets

STEP 1:

- Stand the Back Panel and the Side Panel up using someone to support the panels while they are screwed together.
- Before fixing, ensure that the Side Panel overlaps the Back Panel.
- Using 8 x 40mm screws, screw the Top and Bottom Plates together.

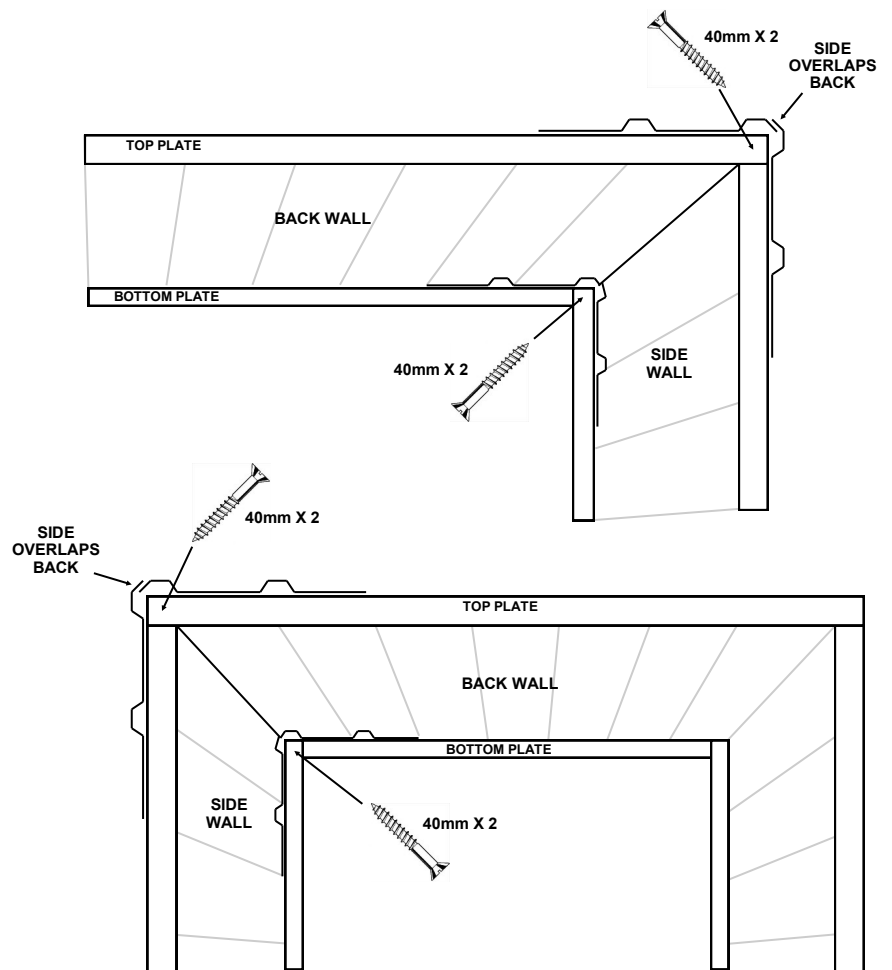

STEP 2:

- Repeat Step 1 with the second Side Panel, ensuring that the Side Panel overlaps the Back Wall Panel.

STEP 3:

- Stand up the Front Wall Panel.
- Ensure that the Front Wall Sheets overlap the Side Wall Sheets.
- Using 4 x 75mm screws (2 per join) screw the Top plates together in the corners, and 4 x 40mm screws for the Bottom plates.

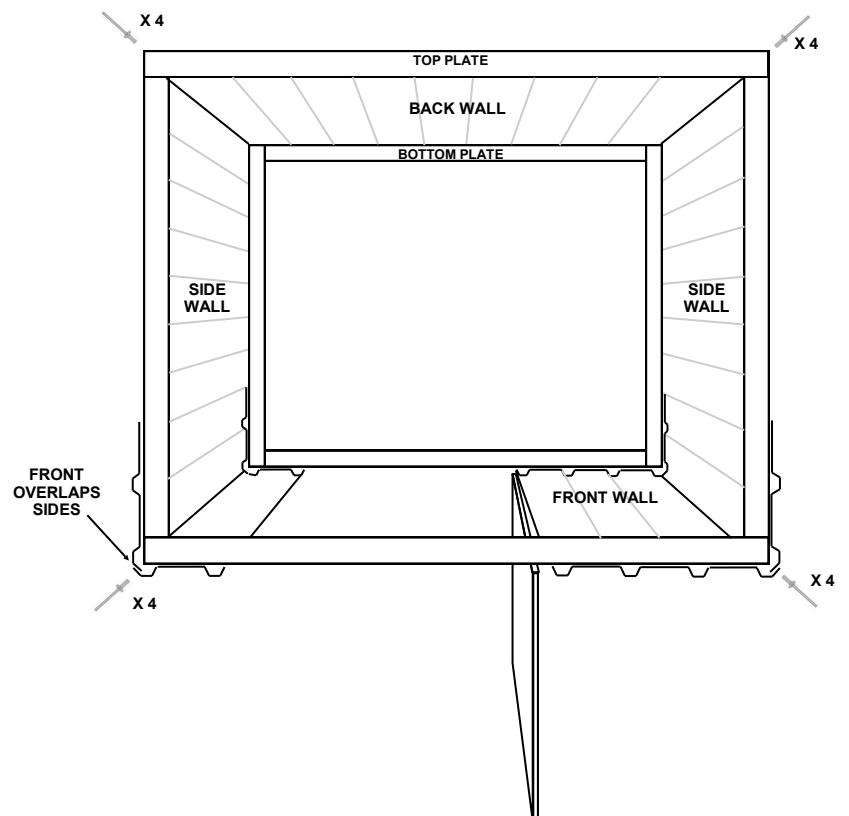

STEP 4:

- Rivet the wall sheets together at the corners using 4 equally spaced rivets as shown.



SELECT:

- 3 x 0.885 Roof Sheets
- 1 x 1.550 Spouting
- 2 x 0.885 Barges
- 20 x 40mm Weatherseal Nails
- 20 x Rivets

IMPORTANT—FOR SHEDS WITH OPTIONAL CLEAR ROOF PANEL

Assemble as below, making sure that the Clear Roof Sheets overlap the standard roof sheets on both sides. The Clear Roof Panel must be secured to the front and back Top Plates. Pre drill and fasten with the 40mm weatherseal nails provided..

STEP 1:

- Ensure Shed is sitting level and square.
- Lay Roof Sheets on the Top Plates (with slots at front).
- Rivet sheets together at overlaps with 1 x rivet per join.

fig.1

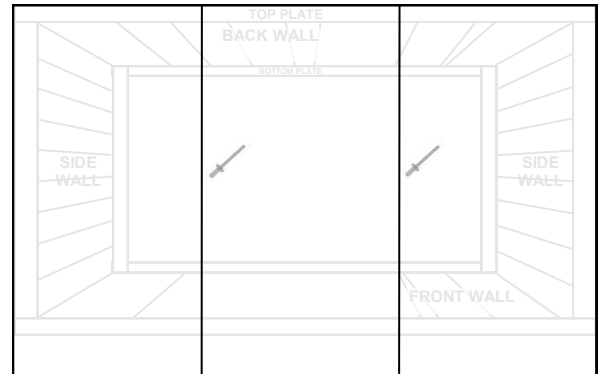

STEP 2:

- Position the Roof Sheets with front overhang of 130mm at each front end (**fig. 1**).
- Using 4 x 40mm weatherseals, nail the Roof Sheets to the Top Plates at each corner, ensuring ribs on the Roof Sheets line up with ribs on the Wall Sheets (**fig.3**).

STEP 3:

- Ensure the Front and Back Top Plates are straight. Nail the roof sheets to the front & back Top Plates, using 1 x nail per pan (**fig.2**).

fig.2

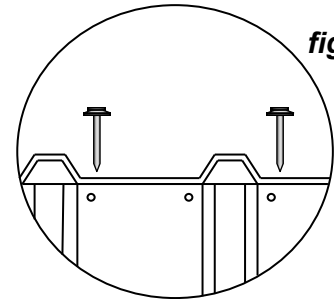

STEP 4:

- Place barge flashings on roof at end of shed ensuring the diagonal trimmed end is at the front.
- Rivet the Barge Flashings to the roof and the side wall, using four rivets on top of barge and four into the side (**fig.3**).

fig.3

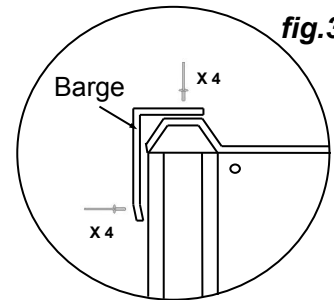

STEP 5:

- Place spouting in position and rivet to Barge Flashings at each end and rivet to roof sheets (1 Rivet per 1 Sheet).



Secure your shed using Treated Timber Pegs or a Bolt Down Kit

TIMBER PEGS—WOODEN FLOOR

- The optional Smart Store Timber Peg Down Kit includes six H5 treated timber pegs that can be hammered into the ground and then attached to the Base Plate with stainless steel screws. A Sentry timber floor can then be fitted on top of the Base Plate.



BOLT DOWN KIT—CONCRETE

- The optional Smart Store Bolt Down Kit includes 6 x galvanised brackets, screws and dynabolts.
- Space the brackets evenly around the shed and fix to the Bottom Plate and the concrete slab. A 10mm masonry drill bit is required.



OPTIONAL SENTRY FLOOR

- Position the Floor Joists centrally between the side Base Plates and skew nail each end with two 75mm nails.
- Check that the shed is sitting level and square and that the diagonal Bottom Plate measurements are the same.
- Place the floor boards in position and nail securely (6 x 50mm nails per board).

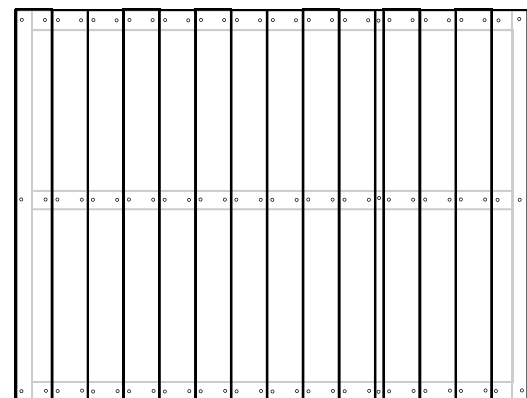
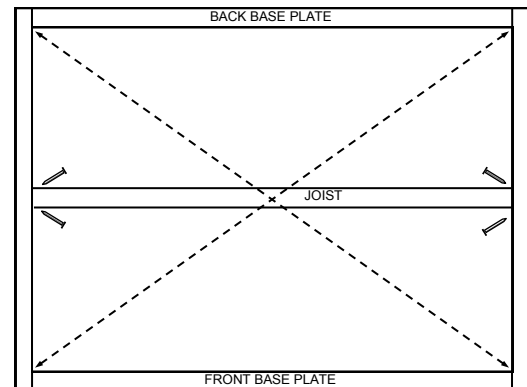

FIT PADBOLT

- Rivet Padbolt to door and keeper onto Door Jamb as shown.



IMPORTANT— CLEAN UP

REMOVE ALL DRILL FILINGS FROM ROOF, WALLS AND CHANNELS THOROUGHLY. FAILURE TO DO THIS WILL RESULT IN CORROSION AND COULD THEREFORE VOID THE WARRANTY.

YOUR SMART STORE SHED IS NOW COMPLETE. RELAX.....



15 YEAR WARRANTY

Riverlea Group Ltd warrant that the cladding used in the manufacture of the Smart Store shed will not rust within 15 years from the date of purchase.

Any liability for product failure that may arise will be limited to repair or replacement of the defective product and will only apply for the benefit of the original purchaser. Riverlea Group Limited will not be liable for any consequential loss or damage, labour, or transport charges.

This warranty is conditional on:

- Construction, installation and maintenance being carried out as specified in the Assembly Instruction Manual.
- The shed being installed in modest inland corrosion zones or areas where the steel corrosion rate is less than 200g/m² (as published by Branz).
- Warranty certificate being returned to manufacturer within 21 days of purchase together with proof of purchase.

This warranty does not cover the following:

- Fastenings and fixings.
- Normal wear and tear, damage by impact or acts of God.
- Situations where the shed has been used for storage of chemicals, manure or corrosion causing products.
- Unauthorized modification of the structure, including painting of the cladding.

WARRANTY REGISTRATION

Please visit <http://www.riverleagroup.co.nz/warranty-garden-sheds> to validate the Warranty on your shed. Click on the Warranty Registration Link and complete all details.

If you are unable to access the computer, please phone us on 0800 438 274 and one of the customer services team will help you to activate the warranty on your garden shed.

Many thanks, from the Team at Riverlea Group.