

Duraturf[®] KIWI SHEDS

Quality - Built In

ASSEMBLY INSTRUCTIONS



DKE1742-SS

DOOR IN END

BASE SIZE 4210mm x 1715mm

ASSEMBLY INSTRUCTIONS

Tools Required:

- Drill
- Drill Bit 3.5mm
- Drill Bit 10mm
- Drill Bit 6mm (for clear roof panel only)
- Riveter
- Hammer
- Nail Punch
- Tape Measure
- Ladder or Saw stool
- Long nosed Pliers
- String Line
- Tin Snips
- Skillsaw and Jigsaw (for floor only)
- Masonry Drill and 10mm Masonry Bit (for Bolt Down Kit only)

Before you start:

- Read all instructions carefully.
- Identify all parts and check quantities against checklist.
- If you are making your own floor refer to Raised Base Plate section now.

Safety:

- Do not attempt to build your shed in high winds.
- Beware of sharp edges.
- Protect your eyes and ears.
- Use electric tools with care. Use a Safety Trip Switch.
- It is easier and quicker if this shed is erected by two people.

Select your site:

- Your shed must be level. Achieve this by either levelling the ground or by using blocks.
- **Your shed should not be positioned directly on the ground. We strongly recommend that your shed is raised up off the ground by at least 40mm. See the Warranty page for more information.**

ROOF COLOUR WALL COLOUR INVOICE NO: BASE SIZE:

QTY	LENGTH	DESCRIPTION	PACKED	CHECKED
			<input type="checkbox"/>	<input type="checkbox"/>
2	0.200m	Gable End Wall Sheets (Door End)	<input type="checkbox"/>	<input type="checkbox"/>
2	2.080m	Gable End Wall Sheets	<input type="checkbox"/>	<input type="checkbox"/>
11	1.890m	Wall Sheets	<input type="checkbox"/>	<input type="checkbox"/>
1		Door - Standard <input type="checkbox"/> Security <input type="checkbox"/>	<input type="checkbox"/>	<input type="checkbox"/>
1		Instruction Booklet	<input type="checkbox"/>	<input type="checkbox"/>
1	0.200m	Jack Studs - 70 x 45mm	<input type="checkbox"/>	<input type="checkbox"/>
1		Hardware Pack	<input type="checkbox"/>	<input type="checkbox"/>
1		Centre Door Stop	<input type="checkbox"/>	<input type="checkbox"/>
		Touch-up Paint & Brush	<input type="checkbox"/>	<input type="checkbox"/>
1		Duratuf Riveter	<input type="checkbox"/>	<input type="checkbox"/>
5	2.000m	Roof Sheets	<input type="checkbox"/>	<input type="checkbox"/>
			<input type="checkbox"/>	<input type="checkbox"/>
			<input type="checkbox"/>	<input type="checkbox"/>
			<input type="checkbox"/>	<input type="checkbox"/>

OPTIONAL EXTRAS

QTY	LENGTH	DESCRIPTION	PACKED	CHECKED
230	50mm	Flooring Nails	<input type="checkbox"/>	<input type="checkbox"/>
12	75mm	Flooring Nails	<input type="checkbox"/>	<input type="checkbox"/>

WINDOWS

		Fixed Window Frame	<input type="checkbox"/>	<input type="checkbox"/>
	0.580m	Glaze Beads	<input type="checkbox"/>	<input type="checkbox"/>
	0.603 x 0.603m	Glass	<input type="checkbox"/>	<input type="checkbox"/>
			<input type="checkbox"/>	<input type="checkbox"/>
		Louvre Window Frame	<input type="checkbox"/>	<input type="checkbox"/>
	0.588 x 0.150m	Glass	<input type="checkbox"/>	<input type="checkbox"/>
	0.710 x 0.240m	Over Panel	<input type="checkbox"/>	<input type="checkbox"/>
1		Window Hardware Pack	<input type="checkbox"/>	<input type="checkbox"/>

CLEAR ROOF PANEL

	2.000m	Roof Sheets	<input type="checkbox"/>	<input type="checkbox"/>
	0.975m	Flat Roof Sheet	<input type="checkbox"/>	<input type="checkbox"/>
	0.975m	Clear Roof Panel	<input type="checkbox"/>	<input type="checkbox"/>
	0.350m	Pressed Capping Sheet	<input type="checkbox"/>	<input type="checkbox"/>
	0.900m	Bevel Edge Support 45 x 45mm	<input type="checkbox"/>	<input type="checkbox"/>
1		Clear Roof Hardware Pack	<input type="checkbox"/>	<input type="checkbox"/>

SECURITY PARTS

		Security Double Door Hardware Pack	<input type="checkbox"/>	<input type="checkbox"/>
		Alarm - MA20	<input type="checkbox"/>	<input type="checkbox"/>
		Shed light	<input type="checkbox"/>	<input type="checkbox"/>
		Bolt Down Kit	<input type="checkbox"/>	<input type="checkbox"/>
		Peg Down Kit	<input type="checkbox"/>	<input type="checkbox"/>

DATE: / /

PACKED BY:

CHECKED BY:

Total Weight kg

DKE1742-SS TIMBER FRAME

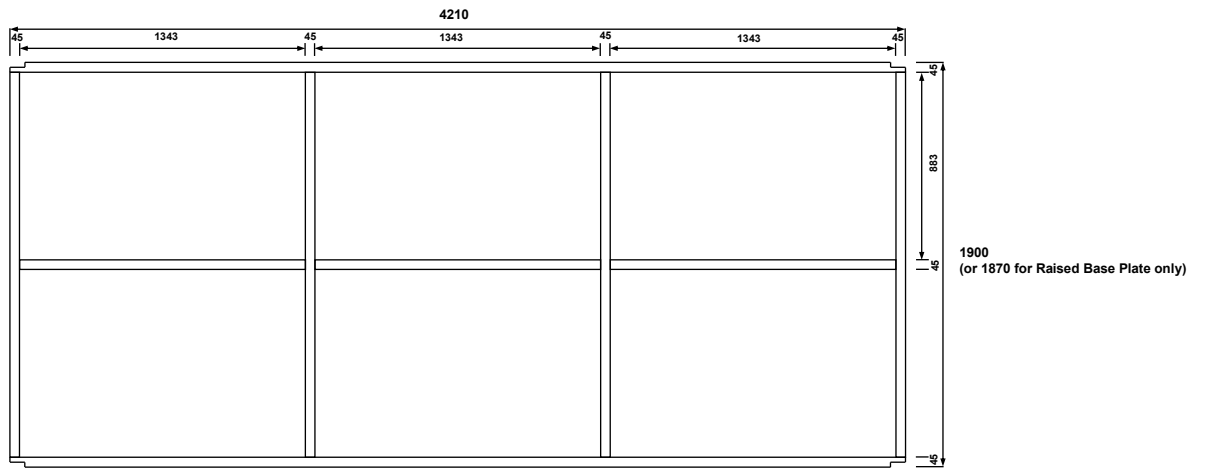
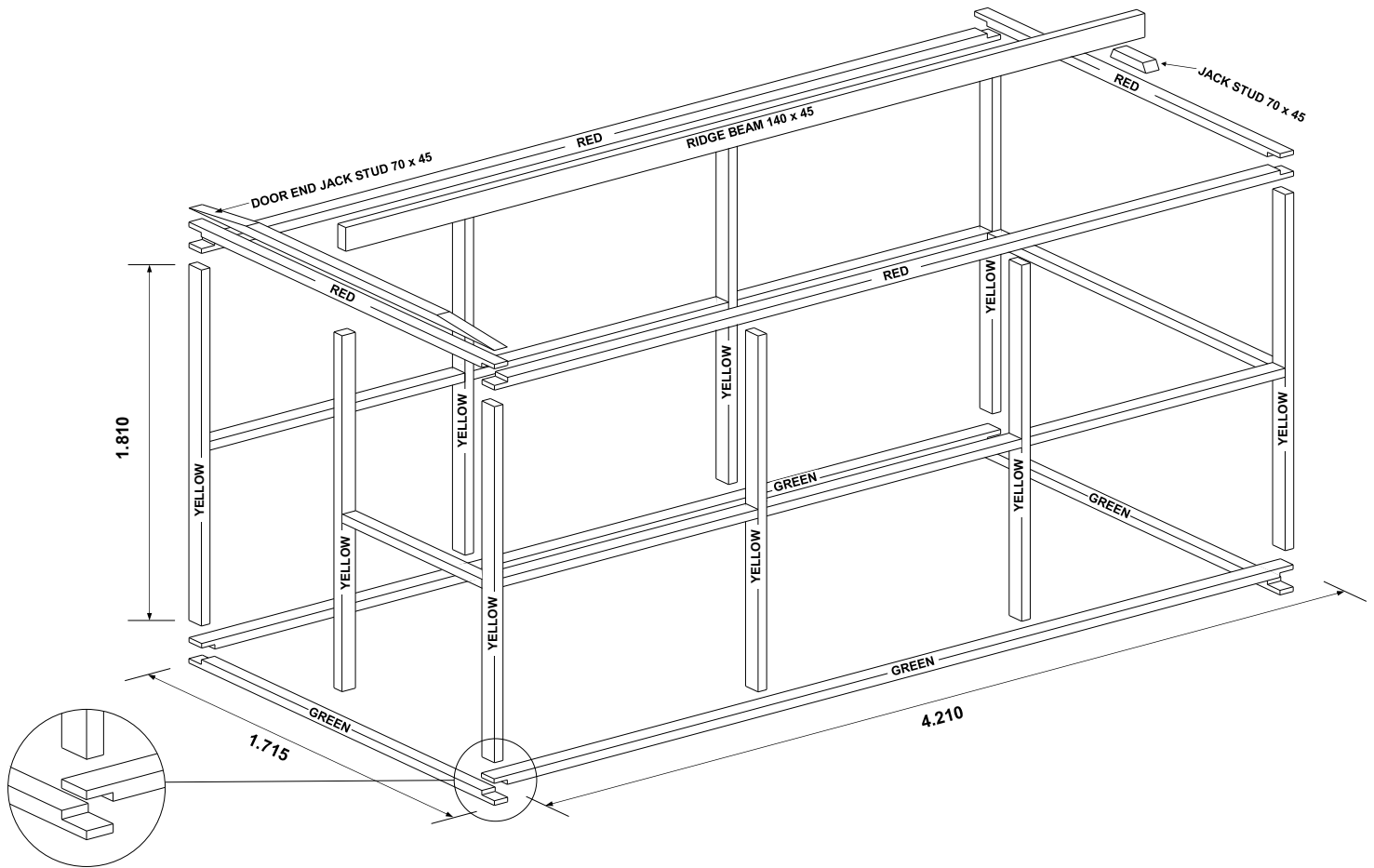

BACK WALL

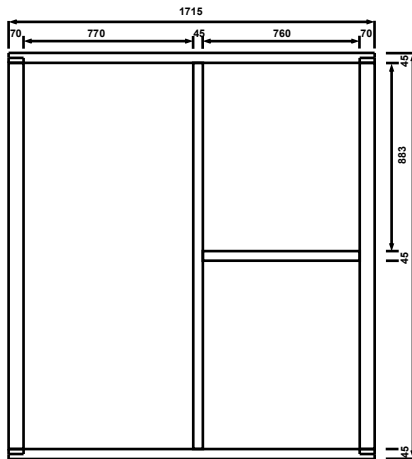

DOOR END WALL

DKE1742-SS TIMBER FRAME

Note: If fitting a window in the back wall, there will be no centre stud on that side. Instead nail in a full length Nog (4.120) using window studs (.883) to get correct height. Position one window stud centrally beneath the Nog and nail in place. Further window studs and Nogs are fitted after the cladding is on.

Step 1: Back Wall: Select one 4.210m Base Plate (Green), one 4.210m Top Plate (Red) and four Studs (Yellow). Lay out Plates and two Studs on a flat surface and nail together using two 75mm nails per join. Nail in remaining centre studs using 1.343m Nogs to get correct position. Position Nogs .883m from Top Plate and nail in place.

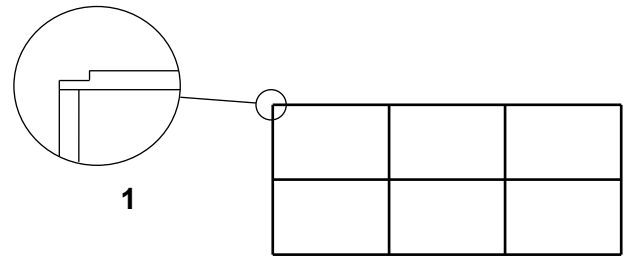

Step 2: Front Wall: Repeat step 1 for front wall.

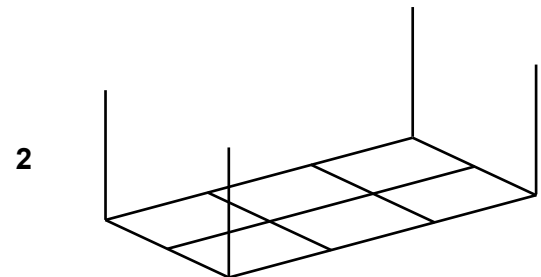

Step 3: Select two 1.715m Base Plates (Green) and two 1.715m Top Plates (Red). With front wall lying on the ground, nail Plates to frame. Ensure Green joins to Green and Red joins to Red.

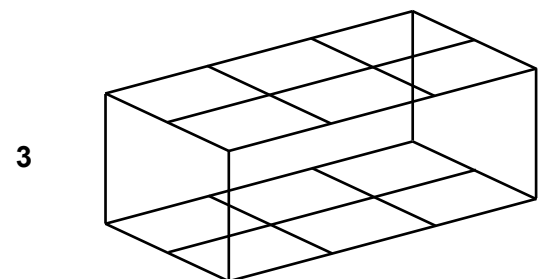

Step 4: Position the back wall frame on top of plates. While someone supports frame, nail in place.

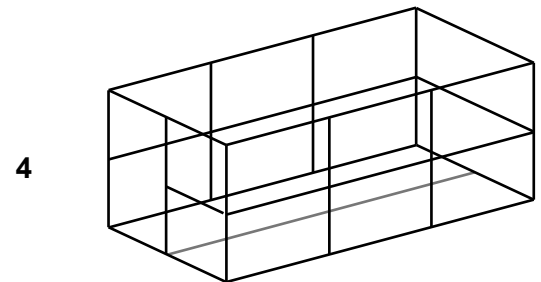

Step 5: Carefully roll frame over onto its base. (Pieces of timber from the packaging may be used to temporarily brace the frame before rolling it over). Position 1.575 End Wall Nog .883m down from Top Plate and nail in place. Nail 0.770m Door End Nog in place. If fitting a Kiwi Floor, fit Floor Joist now. Space joist centrally and nail in place

fig. 1

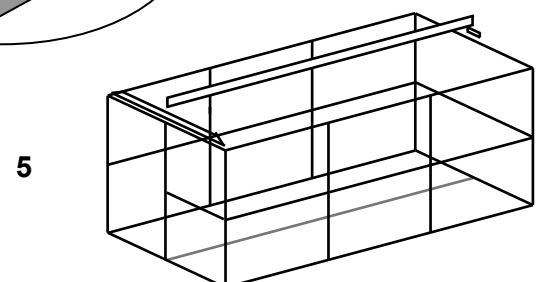
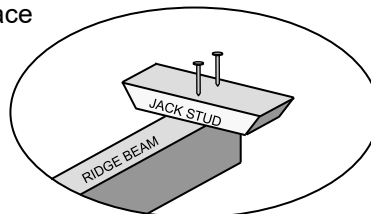

Step 6: Position a Jack Stud and Door End Jack Stud on each end of Ridge Beam and nail in place using two 75mm nails each end (**fig. 1**). Turnover Ridge Beam / Jack Studs, position centrally on 1.715m Top Plates and nail to Top Plates using 75mm nails.

DKE1742-SS WALL CLADDING

Step 6: Nail Over Door Weather Flashing to Door End Jack Stud with 30mm clouts.

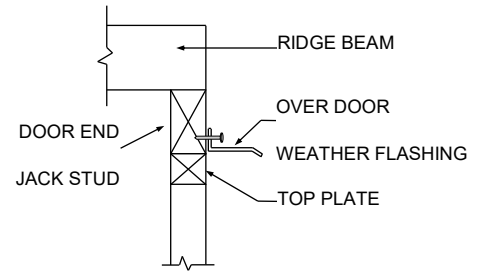

TO AVOID CORROSION:

- Where at all possible try not to trap metal filings between two sheets. Remove all metal filings before riveting.
- Carbon in pencils reacts with the Zinc/Aluminium coating on steel. Use ink to mark steel.

TERMS EXPLANATION

- **To Tack:** To Tack on a wall sheet means to use minimum nails hammered partly in to hold Wall Sheets in position. Should a Wall Sheet need to be re-positioned, the nails can easily be prized out.
- If a window is required, identify Wall Sheet(s) with window hole pre-cut. Lean up Wall Sheets where window(s) are to be located.

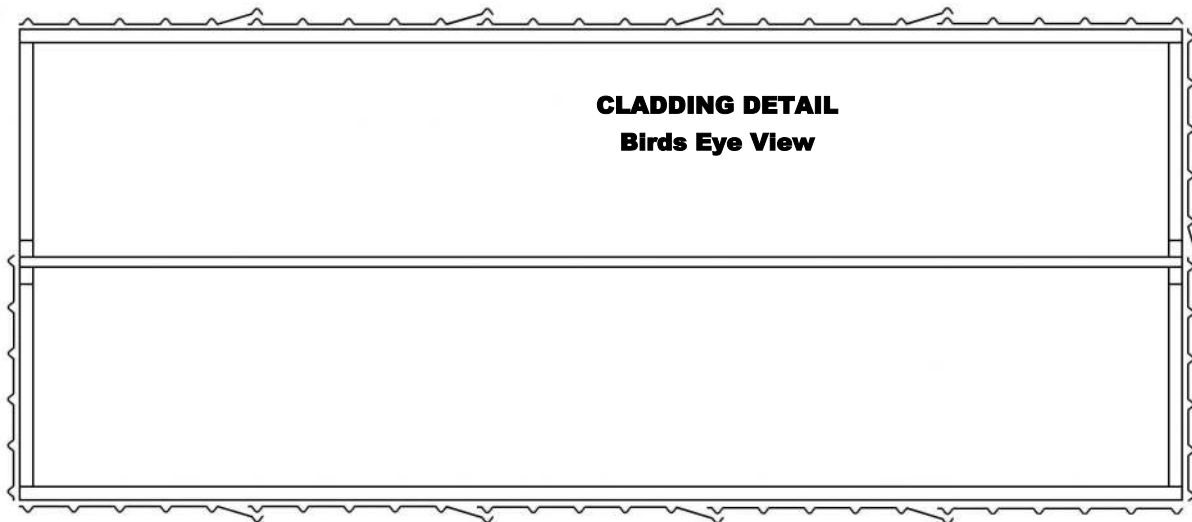

Note:

When fitting Gable End Sheets ensure they overlap correctly (**fig 1**).

The overlap direction may differ from cladding detail below.

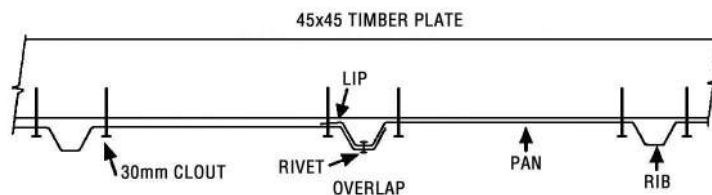
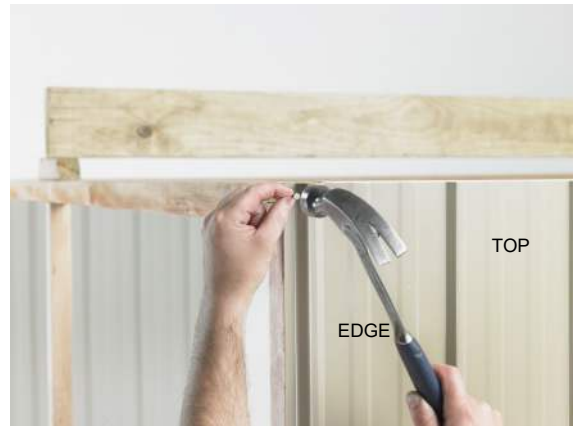

fig. 1

DKE1742-SS WALL CLADDING

Note: For sheds with the Raised Base Plate option, the Wall Sheets will protrude 20mm below the Bottom Plate. Refer to Raised Base Plate section (page 14).

Step 1: Front Wall: Start at the left hand side. Position the Wall Sheet with the LIP on the left hand side. Ensuring the LIP is flush with side of the Stud and the top of the Top Plate, tack in place. Position the next Wall Sheet with the LIP on the left hand side. Overlap as shown in **Cladding detail**. Ensuring Wall Sheet is flush with the top of the Top Plate, tack in place. Repeat with remaining three sheets.



Step 2: Back Wall: Position the first Wall Sheet with the LIP on the right hand side. Ensuring the LIP is flush with the side of the Stud and the top of the Wall Sheet is flush with the top of the Top Plate, tack in place. Position the next Wall Sheet with the LIP on the right hand side. Overlap as shown in **Cladding detail**. Ensuring Wall Sheet is flush with the top of the Top Plate, tack in place. Repeat with remaining three sheets.



Step 3: End Wall: Lean Gable Wall Sheets against the shed to form gable shape. With the LIP flush with side of Stud tack in place ensuring the bottom of the Wall Sheet is 10mm above the bottom of the Bottom Plate. Tack on remaining Wall Sheet.

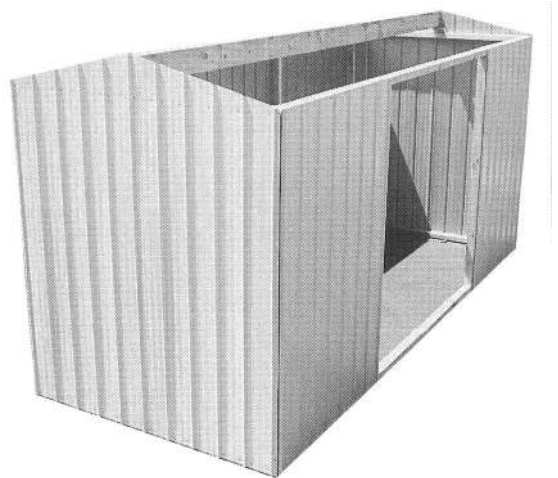

Step 4: Door End Wall: Position Wall Sheet to side of the door. Tack the sheets in place ensuring sheet is flush with corner stud and hard up underneath the Over Door Weather Flashing. Check doorway is square before nailing off the Door End Wall. Nail 200mm sheets to the Door End Jack Stud.

Step 4: Nailing Off: Nail one 30mm Clout each side of the Rib (two per Pan) into the Top Plates and Bottom Plates. Nail Wall Sheets to mid wall Nogs (one per pan). Nail each corner Wall Sheet to Studs using two 30mm Clouts evenly spaced.

Gable Ends: When nailing Gable Wall Sheets to the Top Plate, use a String Line. At the top of the gable nail two 30mm Clouts into the end of the Ridge Beam. This will stop it from twisting.

DKE1742-SS FIXED WINDOW (Optional)

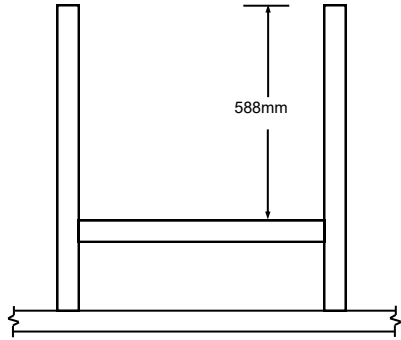

Step 1: Lay out the two window studs (883mm) and Nog (634mm) on a flat surface. Position Nog and nail in place using 2x 75mm nails at each end.



Step 2: On the inside of the shed, position studs and Nog centrally on window opening. Make sure the studs are parallel and nail into Top Plate and End Wall Nog.



Step 3: Nail wall Sheets to window framing using 30mm clouts. (return to step 4 on page 7 and complete). Then fit Window Frame. Position Window Frame centrally on window opening and rivet it to ribs. Pre-drill holes in each corner and nail Window Frame to framing, using 50mm nails.



Step 4: If the Window is in the gable end, temporarily position the Over Panel above Window Frame. Following the same angle as the gable, mark and cut to suit.



Step 5: Rivet Over Panel to the Window Frame with rivets.



Step 6: From the inside of the shed, slide Louvre Glass into Louvre Units attached to the Window Frame. Bend up tabs to keep Glass in position.

DKE1742-SS FIXED WINDOW (Optional)

Step 1: Lay out the two window studs (883mm) and Nog (590mm) on a flat surface. Position Nog and nail in place using two 75mm nails at each end.

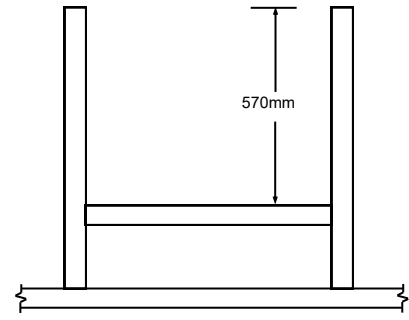

Follow Steps 2 - 5 on page 8.

Step 6: From the outside of the shed, place glass in Window Frame. Attach a Glazing Bead (G100) with three rivets to each side of the Window Frame to hold glass in place. Pre-drilling Glazing Beads is recommended.



DKE1742-SS DOOR JAMB & CORNER FLASHINGS

Step1: Fit Door Jamb Flashing (104) in between Top and Bottom Plates and hard against Stud. Attach Door Jamb Flashing with three rivets into Rib on the outside and three 30mm clouts into studs on the inside. Repeat with the other Door Jamb.



Step 2: On the left hand side of the front wall fit Corner Flashing (101) over Door Jamb Flashing and rib . With top of the Corner Flashing flush with the top of the Top Plate, rivet in place using six rivets.

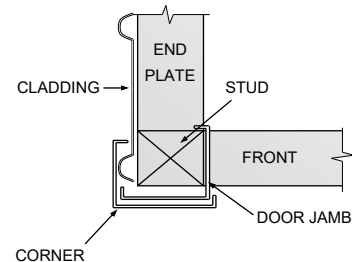

Step3: Measure and cut Doorstep Flashing (106) to fit in between Door Jambs. Position the Doorstep Flashing in between the Door Jambs at bottom of doorway, nail through top of flashing using three 30mm Clouts. Repeat with the Overdoor Flashing (105).



Step 4: Fit remaining three Corner Flashings over corner Ribs and rivet in place using six rivets per flashing. When fitting right hand Corner Flashing on the front wall, ensure it is parallel with the Door Jamb.



DKE1742-SS DOOR

Step 1: Position Door Track (107) on End wall up against underside of Over Door Flashing, with right hand end 20mm in from outside of the right hand corner flashing.

Pre-drill a hole in the centre of the track and screw in place using one 45mm door track screw. Remove ALL drill filings

Note: Ensure Door Track screws are screwed in horizontal and screwed hard into flashing. Protruding screw heads can cause door rollers to bind on the screw heads.

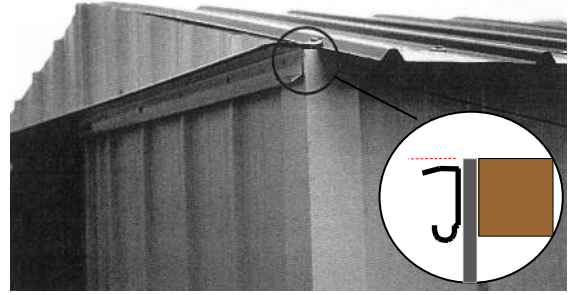

Step 2: Hang the door in the Door Track. At the right hand end of Door Track, adjust up or down so that the Door hangs parallel with shed. Fit one rivet at right hand end to hold in place. Repeat with left hand end of track.

Note: Only use rivets at each end of track.



Step 3: Remove the Door. Pre-drill and screw another 2 screws between the centre screw and the rivets at each end (5 screws per track). Screw track using 45mm door track screws.

Step 4: Clean out ALL drill filings. Also make sure the Wheels are cleaned of drill filings. Re-hang Door.

Door Stops: Pre-drill a hole in right-hand end of track, 45mm in from outside edge of Corner Flashing.

Pre-drill hole in left-hand end of track, 45mm from outside edge of corner flashing. (60mm for Security door option.)

Screw door stops in using 1 x Roofing screw per stop.

Check door doesn't protrude past outside edge of shed.



Step 5: Bottom Door Guide: Slide the Door to the corner of the shed. Place the Door Guide (108) over the Guide Brackets on the door and align the end of the Door Guide 20mm in from outside of the right-hand corner flashing.

Step 6: Lift the door guide up approximately 3mm so that the Door will Slide freely. Pre-drill a hole through the door guide and the end rib of the cladding and screw in place using a 45mm screw.

Step 7: Slide the door to the centre, ensuring that it slides freely. Pre-drill and insert a screw in the other end of the Door Guide. Check that the Door is not binding in the middle then pre-drill and fix with 3 more screws, one in the centre of the guide and the other 2 evenly spaced between (5 screws per guide) into the door step flashing and rib.

Note: For sheds with Raised Base Plate option the Door Step Flashing will protrude down past the Bottom Plate. Attach Door Guide with rivets.

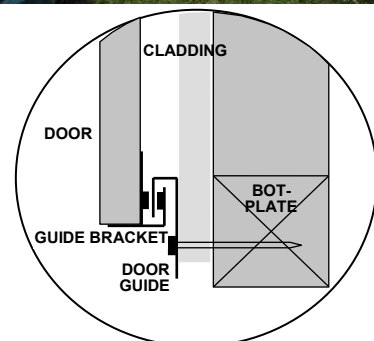

DKE1742-SS ROOF

Note: Condensation can form on the under side of shed roof. If building paper is required, fit now. Building paper will need to be supported by netting or roofing twine.

Step 1: Check that the diagonal measurements of the shed are the same. If building on unlevel ground it may be necessary to temporarily brace the shed with pieces of timber from the packaging.

Step 2: Position first Roof Sheet centrally over Ridge Beam on the right hand end of shed with the LIP on the left hand side. (For sheds with a Clear Roof Panel, go to the next page). Position the next Roof Sheet. Ensure it overlaps correctly then rivet together, 400mm down from the centre on both sides. Fit remaining Roof Sheets.



Step 3: Starting from the left hand end, centralize Roof on Ridge Beam. Ensure Roof is tight against end Wall Sheets, predrill then nail one 50mm Clout through Rib into the Ridge Beam. At the back, line up Ribs on the Roof Sheet with the Ribs on Wall Sheet. Using one 50mm Clout, nail through Rib into Back Top Plate. Repeat at the front.

Note The 6 x 50mm Clouts on end ribs are covered by the Barge Flashings.

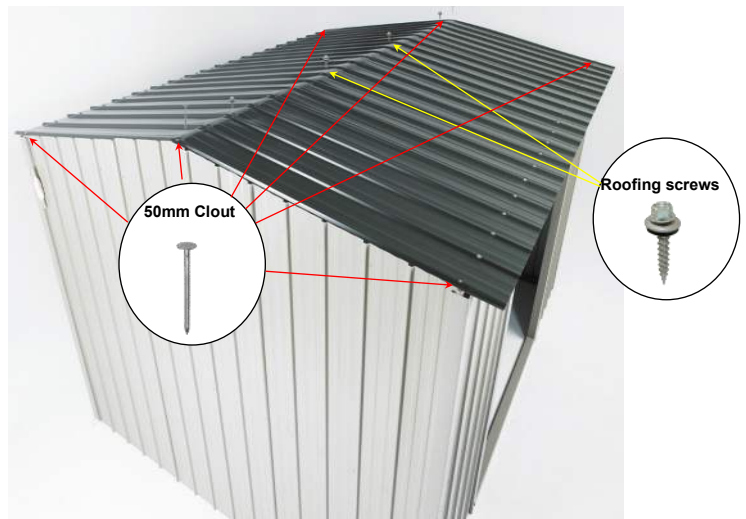

Step 4: Centralize Roof at the other end and nail through Rib into the Ridge Beam and Top Plates, using 50mm Clouts. Ensure Ridge Beam is straight, then Screw one 50mm Roofing Screw into Ridge Beam through each Rib on overlap (one screw per sheet). At the back, set up a String Line in centre of Top Plate. Ensure Top Plate is straight and screw, using one 50mm Roofing Screw per Rib. Repeat at the front.



DKE1742-SS BARGE & SPOUTING



Step 1: Position Barge Flashing (A102) on gable ends. Cut Barge at Door End to fit around Over Door Weather Flashing as shown. Position a Spouting (D103) and rivet to the Barge Flashing at each end. Repeat with other Spouting.



Step 2: Centralise Barge Flashing on gable end and rivet in place, one rivet into every second Rib. Fit two rivets through top of Barge into Rib. Repeat with other Barge Flashing. Check Spoutings are straight, then rivet to Roof one rivet every second Rib.

DKE1742-SS FLOOR

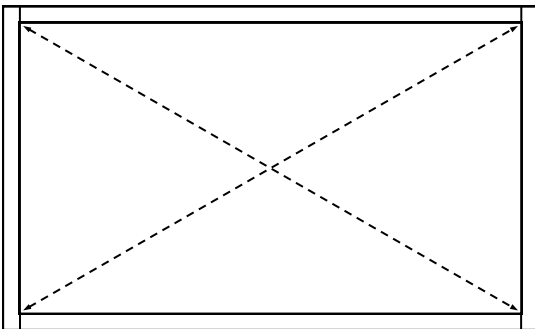

Step 1: Place shed in final position. Check the diagonal measurements are the same and the shed is level before fitting Floor. It is recommended that the shed is anchored down with either a Duratuf Bolt Down Kit or Duratuf Peg Down Kit depending on what the shed is sited on.



Step 2:

Lay a Floor Board on top of Bottom Plates and Joist and push up against end wall. Mark out where Studs are. Cut checkouts with Electric Jigsaw so Floor Board will fit around Studs.



Step 3: Re-position Floor Board. Lay out remaining Floor Boards checking around Studs as you go. The last Floor Board may have to be cut to size.



Step 4: Nail in each Floor Board, two 50mm nails in each end and two into Joist. Measure and cut Floor Flashing (110) to fit in between Door Jamb Flashings and nail in place using 50mm Clouts.

SECURITY DOOR (Optional)

Step 1: Attach " T" locking handle with two 8x10mm screws. Slide hook onto square shaft and secure with a lock washer.

Lock Washer

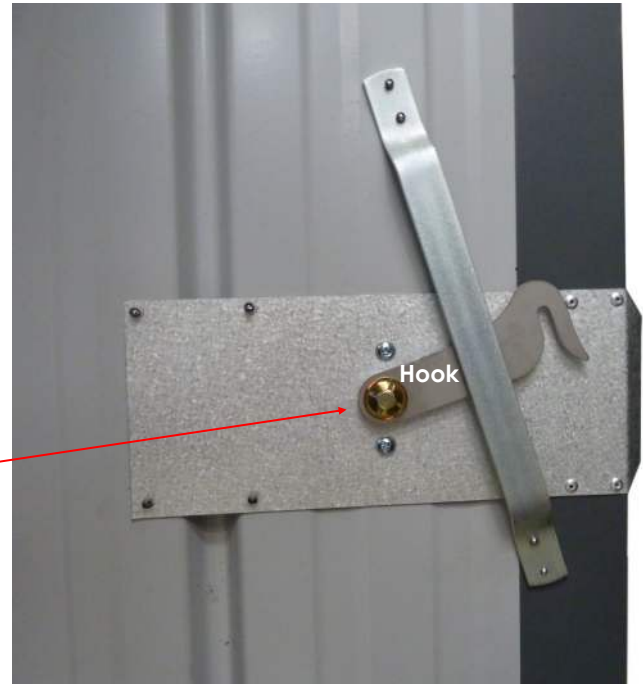

Step 2: Once door is hung, position the Locking Stays so they slide into the Locking Brackets easily. Screw Locking Stays to Door Jamb.



Step 3 On the left hand Door Jamb, position latch so that the hook on the door handle will be secure and go in and out easily. Rivet in place with four rivets.



DKE1742-SS HASP & STAPLE



Using six rivets and one 50mm clout attach hasp to Door Jamb Flashing and the staple to the Door as shown.

RAISED BASE PLATE

For sheds being placed on a purpose built floor, (concrete, cobbles, ply etc.), the Wall Sheets will protrude 20mm below the Base Plate. This will stop water flowing in between the Base Plate and Floor.

The Floor should be made 15mm smaller than Base Size.

Note: Although it is not essential, fitting Damp Proof Course in between the Base Plate and the Floor will give added protection against moisture.

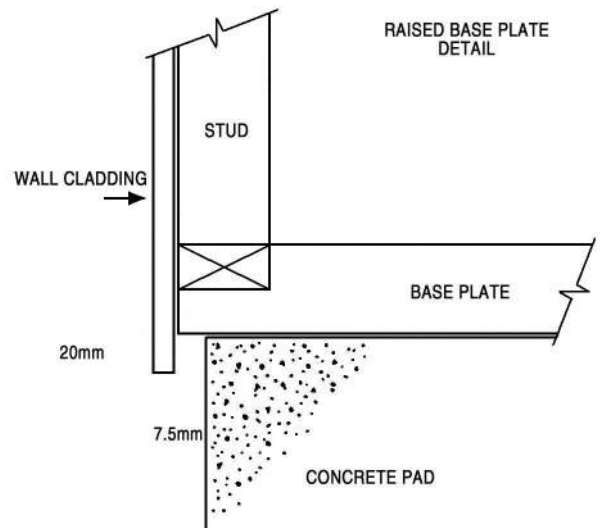

CLEAN UP

- Remove all swarf (drill filings) with a soft brush or rag.
- Hose down roof and walls thoroughly.
- For Coloursteel sheds use touch-up paint provided on all nail heads, rivets and exposed cuts.



DURATUF PREMIUM SHED WARRANTY

GUARANTEE TO CUSTOMER

Congratulations on purchasing a Duratuf Storage Shed. With proper care and attention, this product will last many years.

For your benefit **PLEASE READ THE FOLLOWING INFORMATION CAREFULLY.**

WARRANTY ON METAL CLADDING

Riverlea Group Ltd guarantee that the metal roofing and wall cladding on Kiwi and Fortress Garden Sheds may be used in moderate and inland corrosion zones or areas where the first year mild steel corrosion rate is less than 200g/m², and that in these conditions, they will not perforate due to corrosion within 30 years of date of manufacture.

TERMS AND CONDITIONS

1. Damage or corrosion due to the following circumstances is not covered by this warranty.
 - ◆ Mechanical, chemical or other damage sustained during or after installation.
NOTE: Clean swarf off shed **IMMEDIATELY** after assembly
Do **NOT** mark cladding with pencil
Do **NOT** allow manures, chemicals or other corrosive materials to have direct contact with cladding
Chemical damage will result if these instructions are not carried out
 - ◆ Force majeure or other causes beyond the control of Riverlea Group Ltd.
2. This warranty does not cover material installed in severe and very severe environmental situations, or in any area where the mild steel corrosion rate (as published by BRANZ) exceeds 200g/m².
3. Minimum maintenance must be carried out in accordance with instructions below.

Should the cladding fail to perform as specified above, the liability of Riverlea Group Ltd shall in all cases be limited to replacing or repairing the defective product. The balance of the original warranty will cover any repaired or replaced material. Riverlea Group Ltd will not be liable for any consequential loss or damage, labour or transport charges. All claims made in writing within 21 days of discovery, quoting the reference number at the top right hand corner of this page.

All structural framing and cladding warranties are subject to the shed being installed on a level concrete base, or other solid supports, at least 40mm above ground level, and contact being prevented at all times with soil, vegetation, organic matter, fertilizers, or other moisture retaining substances.

MAINTENANCE

Following are the minimum maintenance requirements for cladding used in Kiwi Garden Sheds and Fortress Sheds.

- ◆ Washing all surfaces by rain, and annual hosing of sheltered areas using a hose and soft nylon brush.
- ◆ Within 2km of coast—wash every 3 months as above. After a storm, wash the cladding and the gutters as soon as possible to remove any highly corrosive salt deposits.
- ◆ Volcanic Ash Fallout—wash as soon as possible, removing fallout from roof and gutters
- ◆ Gutters to be kept clean of leaves and dirt.

Should you require additional technical information please contact us at the details below.

WARRANTY REGISTRATION

Please visit <http://www.riverleagroup.co.nz/warranty-garden-sheds> to validate the Warranty on your shed.

Click on the Warranty Registration Link and complete all details.

If you are unable to access the computer, please phone us on 0800 438 274 and one of the customer services team will help you to activate the warranty on your garden shed.

Many thanks, from the Team at Riverlea Group.